



FUTURE FARMERS OF AMERICA

HERITAGE HALL

The National FFA Organization is dedicated to making a positive difference in the lives of students by developing their potential for premier leadership, personal growth, and career success through agricultural education. FFA uses agricultural education to create real world success.

The FFA is a national organization of students enrolled in agricultural education in 50 states, Puerto Rico, the Virgin Islands and the District of Columbia. Organized in November 1928, the FFA is an integral part of the curriculum in agricultural education departments in the public schools. All students in these programs are to receive instruction in personal leadership, growth and development which can best be achieved through FFA.

Through active participation in FFA, members learn by taking part in and conducting meetings, speaking in public, participating in contests based on occupational skills, earning awards and recognition and becoming involved in cooperative efforts and community improvement. FFA offers opportunities for becoming productive citizens in our democracy.

FFA members believe in leadership, citizenship and patriotism. They believe in free enterprise - freedom under the law - in making their homes, schools and communities better places in which to live and work.

Each state association is charged with the development of the FFA leadership program within the state, operating contests and award programs at the state level, and issuing chapter charters.

GENERAL RULES

- New* 1. **A teacher/advisor/agent must be present for delivery and pickup of exhibits.**
2. Online entries are strongly encouraged. Advisors should call 800-987-3247, ext. 555 or email contests@gnfa.com to obtain required password, which must be obtained by Sept. 18, 2011. Registration deadline is Sept. 20, 2011. **Late entries will not be processed.**
3. **All exhibitors are required to read and abide by the Georgia National Fair General Rules and Regulations.**
4. Open to all bona fide FFA members in the state of Georgia. Entries may be made as individuals or teams of two, but must be submitted through the club advisor. Projects completed by more than two students must be entered as Chapter projects.
5. Students who graduated last year are eligible to enter work completed in their senior year. Exceptions: Dendrology Notebooks and any contest requiring the student's presence at the Fair.
6. **Each exhibitor may enter only one project per class. No project may be exhibited more than one year.**
7. Arrival, release and judging times are listed under each department.
8. Exhibit entry tags and claim checks will be printed and ready to be attached to articles upon arrival at the Fair.
9. **CANCELLATIONS: Please!! If you see that your chapter will not use the space you have reserved by preregistration, call the Fair and leave a message for the FFA coordinator. Large exhibit spaces and minibooths are difficult to deal with when left empty at Fair time. Thanks for your cooperation.**

10. All projects **worthy** of a ribbon will be placed in either the "Blue Ribbon", "Red Ribbon" or "White Ribbon" group when judged.

11. Please check each section for points assigned, for Champion and Reserve Champion awards and for Superior Chapter award information. **Champion and Reserve Champion, where offered, will be chosen from blue ribbon winners only.**

12. Premiums will be offered in all classes and will be paid on the basis of a point system (see sections for points available) and the money available. The standard premium will be 10 cents per point which is paid to the exhibitor.

13. Prize money will be split in case of a tie between Chapter Champions where offered.

14. Premium checks will be mailed to the school within six weeks after the Fair is over.

New 15. Teacher/advisor/agent must check in with fair staff for pickup of exhibits. A Fair employee will work with one teacher/advisor/agent at a time in releasing the entries. Teacher/advisor/agent must sign for release of exhibits. No items will be released without exhibitor claim tags. **There will be no after hours pickup.**



2011 - 2012 STATE FFA OFFICERS

Front Row: (left to right) Brittney Gunter, State V.P. (North Hall); Ben Bennett, State President (Lowndes County); Jake Todd, State Secretary (Oglethorpe County); and Cassidy Gilliard, State V.P. (Lanier County).

Back Row: (left to right) Edward Moore, State V.P. (Perry); Joey Temperly, State V.P. (Berrien County); Ryan Powell, State V.P. (Houston County); and Newt Gilman, State V.P. (East Jackson).

GRAND CHAMPION FFA CHAPTER \$750

The six Chapters placing in either Superior Champion or Reserve Superior Champion from the three divisions of FFA (Ag Mechanics, Horticulture and Forestry) will be eligible to compete for the Grand Champion FFA Chapter. The chapter accumulating the most eligible points will be declared the Grand Champion Chapter.

Co-Sponsored by

THE GEORGIA NATIONAL FAIR

.....

WALKER RHODES TRACTOR COMPANY



Kubota®

GEORGIA NATIONAL 2010 FFA GRAND CHAMPION CHAPTER

PERRY HIGH SCHOOL PERRY, GEORGIA

AGRICULTURAL MECHANICS DEPARTMENT

Online entries (strongly encouraged) or entry forms must be received by Sept. 20, 2011.

Arrival Time: Wednesday, September 28 - Saturday, October 1
(Weekdays 10:00 AM - 5:00 PM)
(Saturday 10:00 AM - 3:00 PM)

***NO SUNDAY DELIVERY**

Release Time: Tuesday, October 18, 10:00 AM - 8:00 PM
Wednesday, October 19, 10:00 AM - 4:00 PM
& Saturday, October 22, 10:00 AM - 3:00 PM

THE FAIRGROUNDS CANNOT BE RESPONSIBLE FOR THE SAFETY OF EXHIBITS LEFT AFTER 3:00 PM OCTOBER 22.

BRING ONLY FINISHED PROJECTS!

- New* 1. **A teacher/advisor/agent must be present for delivery and pickup of exhibits.**
2. **Exhibitors must be preregistered. Entry forms should be received by September 20, 2011.** Online entries are strongly encouraged. Advisors should call 800-987-3247, ext. 555 or email contests@gnfa.com to obtain required password, which must be obtained by Sept.18, 2011. Registration deadline is Sept. 20, 2011. **Late entries will not be processed.**
3. All projects must be completed, although accessories needed to make the exhibit functional are not necessary; i.e., hydraulic jack for a press.
4. Articles exhibited must have been constructed by FFA members either as a part of their agricultural mechanics instruction in agricultural education or as a part of their supervised agricultural experience program.
5. **No chapter may enter more than three of the same mechanics project.** EXAMPLE - a chapter may not enter 4 gun racks, 4 picnic tables, etc.
6. An article may be shown only once at the Georgia National Fair unless extensively modified. Article does not have to be constructed during the year it is exhibited.
7. All articles must be painted or properly treated, such as feeders, etc. All articles must be clean and in a presentable condition even though they may have been used.
8. Divisions will be determined by the scope of the project, i.e., basic construction, size and time necessary to complete the project. Exhibits classification can be changed by division coordinator if necessary.
9. **If there is a question as to the proper category in which an article should be placed, please consult with the area teacher before preregistration.**
10. NOTE: Judges will make final determination of proper classification.
11. Scale model projects must represent off-site projects and must be fully documented with scaled plans, blueprints, work log, photographs, videotapes, etc.
12. Entries will be judged on the basis of workmanship, finish, design, strength, usefulness and suitability.

Agricultural Mechanics Entry Guidelines

SMALL - Projects that measure less than 3' in height, length or width will be classified as a small project.

MEDIUM - Projects that measure 3'1" to 6' in height, length or width will be classified as a medium project.

LARGE - Projects that measure 6'1" or larger will be classified as a large project.

**GEORGIA NATIONAL
SUPERIOR FFA MECHANICS CHAPTER**

1ST PLACE 2ND PLACE

\$500

\$250

The FFA Chapter accumulating the most points from their 15 best projects (which must be 5 large, 5 medium, 5 small projects) in the Agricultural Mechanics Department will be the Georgia National Superior FFA Mechanics Chapter. Projects may come from Reconditioned or Built Projects or a combination of both. The winning chapter will receive \$500 and a plaque. A tie will be broken by the judges based on their ranking of the 15 best projects from each chapter in regard to workmanship, finish, design, strength, usefulness and suitability. A ranking (1 to 10, with 10 being best) will be assigned to each of the 15 projects. The chapter with the most points for the 15 projects will be the winner. The second place chapter will receive \$250 and a plaque.

Tips From Past Judges

1. Project drawing should be drawn to scale, with all dimensions given. A complete list of materials used to build the project and the cost of materials should be included. The drawing may be a hand drawing or computer drawn. Please do not use a photo plan from a book.
2. Reconditioned Projects should have pictures to show judges the work done on the project and a complete list of materials or parts used to restore the project.
3. Judges evaluate the quality of workmanship on each project. They look at the degree of accuracy of the cuts, how the project is assembled, project preparation for finishing and the finished project.

**FFA AG MECHANICS
SUPERIOR CHAPTER
BONUS AWARD**



**CLINCHFIELD, GEORGIA
\$100 Merit Award**

RECONDITIONED PROJECTS

Harold Milligan, Coordinator
(478-289-2552)

Reconditioned projects shall include background information, pictures, parts list, cost and hours of self-labor. *Placings will be lowered automatically if this information is not complete and included with project.*

*There is no limit as to the number of items a chapter may enter per class. However, no chapter may enter more than three of the same mechanics project. **The projects entered in divisions 30101-30106 must have been completed by an individual student or team of two, otherwise the project must be entered as a Chapter Project.** Individuals are limited to one project per class.*

- DIVISION 30101 - LARGE REC. PROJECTS MIDDLE GRADES (6TH-8TH)
- DIVISION 30102 - LARGE REC. PROJECTS HIGH SCHOOL (9TH-12TH)
- DIVISION 30103 - MEDIUM REC. PROJECTS MIDDLE GRADES (6TH-8TH)
- DIVISION 30104 - MEDIUM REC. PROJECTS HIGH SCHOOL (9TH-12TH)
- DIVISION 30105 - SMALL REC. PROJECTS MIDDLE GRADES (6TH-8TH)
- DIVISION 30106 - SMALL REC. PROJECTS HIGH SCHOOL (9TH-12TH)

CLASSES

- | | |
|-----------------------------|-----------------------------|
| 1 Concrete & Masonry | 7 Power |
| 2 Electricity & Electronics | 8 Soil & Water Conservation |
| 3 Machinery | 9 Tools |
| 4 Metal | 10 Wood |
| 5 Plastics & Fiberglass | 11 Other |
| 6 Plumbing & Irrigation | |

Each Class will be awarded points as follows:

<u>LARGE REC. PROJECTS</u>		<u>MEDIUM REC. PROJECTS</u>		<u>SMALL REC. PROJECTS</u>	
Blue	400 points	Blue	200 points	Blue	100 points
Red	200 points	Red	100 points	Red	50 points
White	100 points	White	50 points	White	25 points
HM	No points	HM	No points	HM	No points

DIVISION CHAMPIONS WILL RECEIVE:

Large Reconditioned Projects Champion \$40, plaque & 400 points
Large Reconditioned Projects Reserve Champion \$30, plaque & 300 points

Medium Reconditioned Projects Champion \$30, plaque & 300 points
Medium Reconditioned Projects Reserve Champion \$20, plaque & 200 points

Small Reconditioned Projects Champion \$20, plaque & 200 points
Small Reconditioned Projects Reserve Champion \$10, plaque & 100 points

CHAPTER RECONDITIONED PROJECTS

Harold Milligan, Coordinator
(478-289-2552)

Reconditioned projects shall include background information, pictures, parts list, cost and hours of self-labor. *Placings will be lowered automatically if this information is not complete and included with project.*

There is no limit as to the number of projects a chapter may enter in this division. However, no chapter may enter two of the same type projects.

DIVISION 30107 - CHAPTER RECONDITIONED PROJECTS MIDDLE GRADES (6TH-8TH)

DIVISION 30108 - CHAPTER RECONDITIONED PROJECTS HIGH SCHOOL (9TH-12TH)

CLASS

1 Chapter Reconditioned Projects

Points:

Blue 400 points

Red 200 points

White 100 points

HM No points

DIVISION CHAMPIONS WILL RECEIVE:

Chapter Reconditioned Project Champion \$40, plaque & 400 points

Chapter Reconditioned Project Reserve Champion \$30, plaque & 300 points

BUILT PROJECTS

Harold Milligan, Coordinator
(478-289-2552)

These projects are built from either published drawings or drawings of original design. **Each participant shall furnish a project plan for each project entered, including a bill for materials. Placings will be lowered automatically if plans are not included with project.**

There is no limit as to the number of items a chapter may enter per class. However, no chapter may enter more than three of the same mechanics project. Individuals are limited to one project per class.

DIVISION 30201 - LARGE BUILT PROJECTS MIDDLE GRADES (6TH-8TH)

DIVISION 30202 - LARGE BUILT PROJECTS HIGH SCHOOL (9TH-12TH)

DIVISION 30203 - MEDIUM BUILT PROJECTS MIDDLE GRADES (6TH-8TH)

DIVISION 30204 - MEDIUM BUILT PROJECTS HIGH SCHOOL (9TH-12TH)

DIVISION 30205 - SMALL BUILT PROJECTS MIDDLE GRADES (6TH-8TH)

DIVISION 30206 - SMALL BUILT PROJECTS HIGH SCHOOL (9TH-12TH)

CLASSES

- | | |
|-----------------------------|-----------------------------|
| 1 Concrete & Masonry | 7 Power |
| 2 Electricity & Electronics | 8 Soil & Water Conservation |
| 3 Machinery | 9 Tools |
| 4 Metal | 10 Wood |
| 5 Plastics & Fiberglass | 11 Other |
| 6 Plumbing & Irrigation | |

Each Class will be awarded points based on the same scale as reconditioned projects. See table on page 67.

DIVISION CHAMPIONS WILL RECEIVE:

- Large Built Projects Champion \$40, plaque & 400 points
- Large Built Projects Reserve Champion \$30, plaque & 300 points
- Medium Built Projects Champion \$30, plaque & 300 points
- Medium Built Projects Reserve Champion \$20, plaque & 200 points
- Small Built Projects Champion \$20, plaque & 200 points
- Small Built Projects Reserve Champion \$10, plaque & 100 points

CHAPTER BUILT PROJECTS

Harold Milligan, Coordinator
(478-289-2552)

Built projects shall include a project plan for each project entered, including a bill for materials. *Placings will be lowered automatically if this information is not complete and included with project.*

There is no limit as to the number of projects a chapter may enter in this division. However, no chapter may enter two of the same type projects.

DIVISION 30207 - CHAPTER BUILT PROJECTS MIDDLE GRADES (6TH-8TH)

DIVISION 30208 - CHAPTER BUILT PROJECTS HIGH SCHOOL (9TH-12TH)

CLASS

1 Chapter Built Projects

Points:

Blue 400 points

Red 200 points

White 100 points

HM No points

DIVISION CHAMPIONS WILL RECEIVE:

Chapter Built Project Champion \$40, plaque & 400 points

Chapter Built Project Reserve Champion \$30, plaque & 300 points

MINITRACTOR PULL CONTEST

Dr. Curtis Borne • Coordinator
(478-825-6262)

DIVISION 30301 - JUNIOR MINITRACTOR PULL

DIVISION 30302 - SENIOR MINITRACTOR PULL

WHEN: Tuesday, October 12

CHECK IN: 9:00 AM during the FFA Day at the Fair

WHERE: Bring tractors to the Fort Valley State display in Reaves Arena

CLASS

1 Minitractor Pull

1. The Tractor Pull Contest is open to FFA members who have Agriscience as part of their curriculum. Each school and members are encouraged to have other displays in the Agricultural Mechanics Department (reconditioned projects and built projects).
2. Each school may enter up to five teams. A team will consist of two members. If a school does not have a complete team, a member may participate as an individual.
3. Contestants must obtain tractor pull kits from Fort Valley State University Collegiate FFA; contact Dr. Curtis Borne at 478-825-6262.
4. Minitractors must be six inches to eight inches long, one and three-fourths inches to three inches wide and must weigh more than 12 ozs. (or 340 grams).
5. Scoring will be the same for junior and senior teams based on:

A. Appearance Score judging criteria:

- 25 pts Dimensions 6" - 8" long and 1 3/4" - 3" wide
- 25 pts Tractor weight not less than 12 ounces or 340 grams
- 5 pts Neatness of electrical connections
- 20 pts Paint Job
- 25 pts Overall appearance

B. Tractor Pull Contest

Possible Score

- 10 pts Weight of Tractor
- 10 pts Plus 180 grams (wagon)
- 10 pts Plus 450 grams
- 10 pts Plus 720 grams
- 10 pts Plus 990 grams
- 10 pts Plus 1260 grams

The Best of Show for neatness of electrical connections, paint job and overall appearance and the Best of Show for pulling ability will each be awarded an additional \$25 by the Fort Valley State University Collegiate FFA.

The pulling ability will be judged by adding weights to a wagon weighing 180 grams pulled by the minitractor. The minitractor must pull each additional weight added to the wagon a distance of at least one meter.

6. Points will be added to appearance score for each weight pulled to determine the champion and reserve champion in each division.
7. The Minitractors will remain on display in Heritage Hall until the end of the Fair.

1st 2nd 3rd 4th 5th-7th 8th-10th
\$40 \$30 \$20 \$15 \$10 \$5

- *Division Champion plaque & 400 points
- *Division Reserve Champion plaque & 300 points

HORTICULTURE DEPARTMENT

Exhibit Delivery Schedule: Wednesday, Sept. 28 - Saturday, Oct. 1
Weekdays 10:00 AM - 5:00 PM Saturday 10:00 AM - 3:00 PM
***NO SUNDAY DELIVERY**

Arrival deadline on all exhibits: Saturday, October 1, 3:00 PM
No late registrations will be accepted.

Release Time: Tuesday, October 18, 10:00 AM - 8:00 PM
Wednesday, October 19, 10:00 AM - 4:00 PM
& Saturday, October 22, 10:00 AM - 3:00 PM

- New* 1. **A teacher/advisor/agent must be present for delivery and pickup of exhibits.**
2. **Exhibitors must be preregistered. Entry forms should be received by September 20, 2011.** Online entries are strongly encouraged. Advisors should call 800-987-3247, ext. 555 or email contests@gnfa.com to obtain required password, which must be obtained by Sept.18, 2011. Registration deadline is Sept. 20, 2011. **Late entries will not be processed.**
3. Individuals are limited to **one** entry per class.
Chapters are limited to the following number of entries in each division:
- | | |
|-------------------------------|---|
| Horticultural Research... | 5 |
| Large Displays..... | 1 |
| Plants/Materials..... | 5 |
| Floral Designs..... | 5 |
| Floral Design Contest Entries | 2 |
| Minibooth Exhibits | 5 |
4. All plants must be tagged with Georgia National Entry Tag before judging.
5. Plants must be in the care and ownership of the exhibitor by August 1.
6. Plants must be properly prepared. They should be well rooted in containers appropriate for the size of the plants. Plants should not be rootbound or potbound.
7. Plants must be cleaned of dead foliage, flowers and stems.
8. Plants must be free of insects, diseases and insect damage. Plants with insects and/or disease will be eliminated at CHECK-IN time.
9. The exhibit will be judged on the quality of the plant, not the container. Elaborate and expensive containers will not be considered in the judging of the plants.
10. Landscape design drawings are to be original designs drawn on any weight paper larger than 10 inches by 14 inches. They should include a complete key or legend identifying the materials used in the drawing, including the scale used.
11. An entry may be exhibited only once at the Georgia National Fair unless it has been extensively modified (live plant classes are excluded).
12. **No toxic substance may be used or displayed.** Empty cleaned containers may be displayed.
13. The chapter must assume responsibility for loose tools, accessories or other items. A fastening device should be used to secure items to display.
14. If a plant/project is entered in the wrong division, it will be judged for a ribbon place, but will not be eligible for a Grand Champion or Reserve Champion ribbon.



HORNBUCKLE WHOLESALE FLORIST

A Growing Reputation for Quality ✶ *A Reputation for Quality Growing*

OMEGA, GA MACON, GA LYONS, GA

☎229-528-4215 ☎478-746-3245 ☎912-526-8105

SUPPORTING FFA: Another Group of Excellent Growers



The Superior Horticulture Chapter will also receive a \$150 Gift Certificate from Hornbuckle Wholesale Florist.

Georgia National Superior FFA Horticulture Chapter

1st Place	2nd Place
\$500	\$250

The FFA chapter accumulating the most points out of their 15 highest scoring projects in the Horticulture Department will be the Georgia National Superior FFA Horticulture Chapter. The chapter winning this award will receive **\$500 and a plaque.**

A tie will be broken by the total number of points accumulated for all entries.

The second place chapter will receive **\$250 and a plaque.**

HORTICULTURE CHAPTER DISPLAYS

Dr. Teri Hamlin • Coordinator
706-542-3679

DIVISION 32001 HORTICULTURE CHAPTER DISPLAYS

CLASS

1 Horticulture Chapter Display

2011 THEME - "Sustainable Landscaping" Each year there will be a different theme for the horticulture chapter displays.

A chapter may enter only one exhibit in this division. Entry forms should arrive by September 20, 2011.

Display area to be a triangle 4'x4'x5'6", with a two-sided backdrop of 4'x8' panels hinged together. These panels will be supplied by the Fair and will be in place ready for use by September 28. Chapters may use staples, thumbtacks, or small finishing nails to attach their exhibit. Use of the floor space within the triangle to create a three-dimensional exhibit is strongly encouraged. There will be a 12"x5'6" title board across the top for your use. See sketch below.

Display will be judged on the chapter's ability to put together an attractive, creative and informative display about "Sustainable Landscaping." Displays will be judged as follows: Theme title (10pts), Attractiveness (30pts), Creativity (20pts) and Information related to theme (40pts).

Ribbon	Value
Blue	700 points
Red	500 points
White	300 points
HM	No points

*Champion \$300 & plaque

*Reserve Champion \$200 & plaque

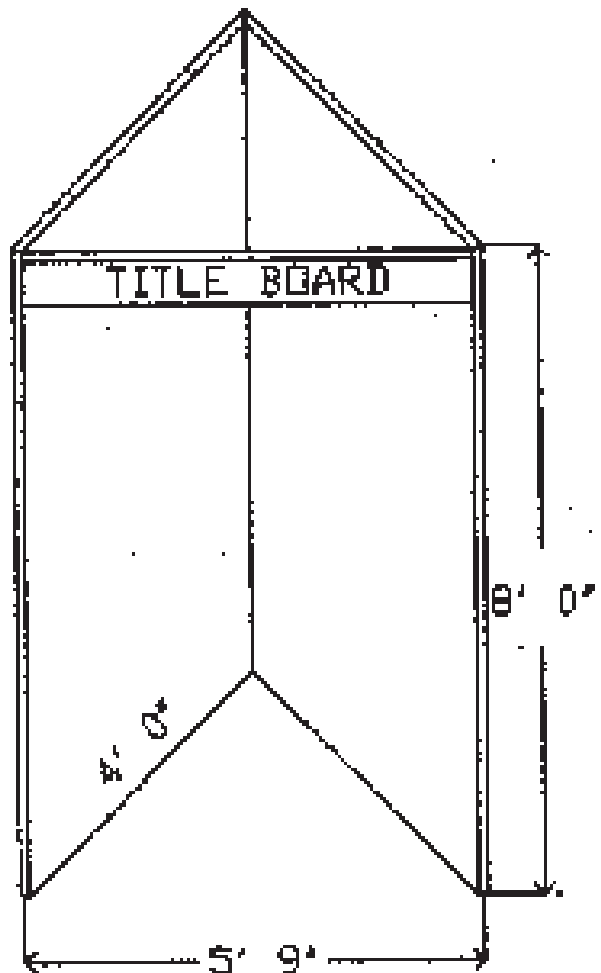

PLANTS/MATERIALS

Dr. Teri Hamlin • Coordinator
706-542-3679

DIVISION 32101 PLANTS/MATERIALS

Individuals are limited to **one** entry per **class** in this division; chapters are limited to a maximum of **five** entries in this division. **All plants must sit in a tray; if not provided, plants will not be watered.** All plants must be in the care and ownership of the exhibitor by August 1. Live plants infested with insects or disease will not be judged and will be removed and discarded. Plants must come from the school with the school and student's name attached. Entries will be judged as follows: Overall Appearance (30pts), Balance & Proportion (25pts), Absence of Pest / Cultural Damage (25pts) and Judges Choice (20pts).

CLASSES	<u>Ribbon</u>	<u>Value</u>
1 Flowering Potted Plants	Blue	100 points
2 Foliage Plants	Red	80 points
3 Hanging Baskets	White	50 points
4 Other	HM	No points

*Division Champion \$40, plaque & 400 points
*Division Reserve Champion \$30, plaque & 300 points

FLORAL DESIGNS

Yvette Smith • Coordinator
229-386-3428

DIVISION 32201 FLORAL DESIGN EXHIBIT

Theme for 2011 Floral Arrangements: "The Beauty of Going Green"

Individuals are limited to **one** entry per **class** in this division; chapters are limited to a maximum of **five** entries in this division. Entries will be judged as follows: Theme (20 pts.), Design (20pts), Technique & Workmanship (20pts), Balance/Color/Interest, (20pts), Functionality (10pts), and Judge's Choice (10 pts).

CLASSES	<u>Ribbon</u>	<u>Value</u>
1 Floral Design (Live)	Blue	100 points
2 Floral Design (Silk/Dried)	Red	80 points
	White	50 points
	HM	No points

*Division Champion \$40, plaque & 400 points
*Division Reserve Champion \$30, plaque & 300 points

HORTICULTURE MINIBOOTH EXHIBITS

Dr. Teri Hamlin • Coordinator
706-542-3679

DIVISION 32301 MINIBOOTH EXHIBITS

Individuals or teams of two are limited to one entry; chapters are limited to five entries in this division. There is no designated theme for this competition.

Exhibits should fit into pre-built display areas provided by the Fair. The display area will be a triangle 30"x30"x36", with a two-sided backdrop of 30"x24" panels hinged together. **POINTS WILL BE DEDUCTED FOR DISPLAYS EXTENDING BEYOND THESE DIMENSIONS.** The display booths are unpainted plywood and are approximately 30" off the floor. **Exhibits must include: theme title, typed or computer generated written information and some type of visual (e.g., pictures, models) related to the theme of the minibooth.** Use of the "floor" of the minibooth to create a three-dimensional exhibit is strongly encouraged.

Displays may be stapled, tacked or taped onto the wooden panels. Do not use glue, paint or nails. **NO ELECTRICITY IS AVAILABLE FOR MINIBOOTHES.**

The exhibit tag furnished by the Georgia National Fair should be placed on the upper right-hand corner of the right partition of the exhibit booth. Minibooths will be judged as follows: Theme title (20pts), Attractiveness (30pts), Creativity (20pts) and Information related to theme (30pts).

*Division Champion \$100, plaque & 400 points
*Division Reserve Champion \$50, plaque & 250 points

<u>Ribbon</u>	<u>Value</u>
Blue	200 points
Red	100 points
White	50 points
HM	No points

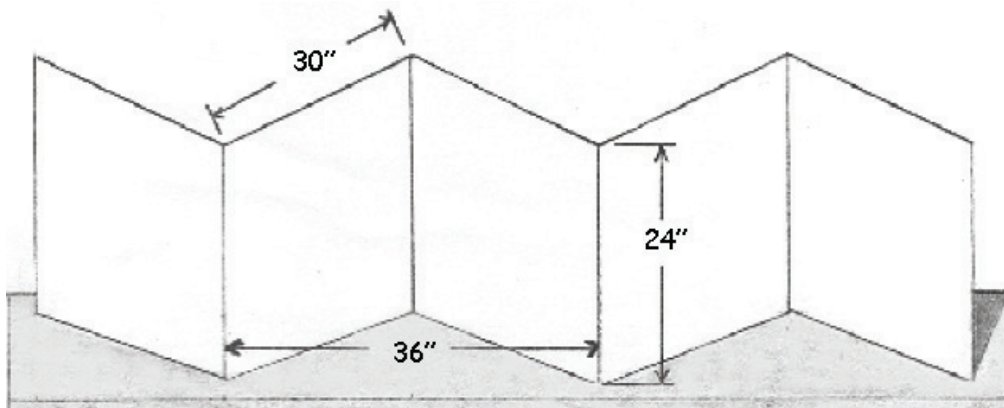

**MINIBOOTH
TABLETOP
DESIGN**

HORTICULTURAL RESEARCH MINIBOOTH

Dr. Teri Hamlin • Coordinator
706-542-3679

DIVISION 32401 HORTICULTURAL RESEARCH MINIBOOTH

A chapter may enter a maximum of five (5) entries in this division. Individuals or teams of two are limited to one entry. There is no designated theme for this competition.

Information in booth must contain typed or computer generated: experiment hypothesis, purpose, materials, procedure, data, results and conclusion. Only projects where a scientific investigation has taken place should be entered.

Exhibits should fit into prebuilt display areas provided by the Fair. The display area will be a triangle 30"x30"x36", with a two-sided backdrop of 30"x 24" panels hinged together. See page 76 for design. **POINTS WILL BE DEDUCTED FOR DISPLAYS EXTENDING BEYOND THESE DIMENSIONS.** The display booths are unpainted plywood and are approximately 30" off the floor. Use of the "floor" of the minibooth to create a three-dimensional exhibit is strongly encouraged. Minibooths will be judged as follows: Hypothesis/Purpose (20pts), Materials (10pts), Procedure (10pts), Data (10pts), Results (10pts), Conclusion (20pts) and Visual Presentation (20pts).

Display may be stapled, tacked or taped onto the wooden panels. **Do not use glue, paint or nails. NO ELECTRICITY IS AVAILABLE FOR MINIBOOTH.**

The exhibit tag furnished by the Georgia National Fair should be placed on the upper right-hand corner of the right partition of the exhibit booth.

Ribbon Value

Blue	200 points	*Champion	\$100, plaque & 400 points
Red	100 points	*Reserve Champion	\$50, plaque & 250 points
White	50 points		
HM	No points		

LANDSCAPE PLANS

Dr. Teri Hamlin • Coordinator
706-542-3679

DIVISION 32501 LANDSCAPE PLANE

Individuals are limited to one entry per class in this division; chapters are limited to a maximum of 25 entries in this division. Entries will be judged as follows: Scale/North Directional (10pts), Symbols/coding (20pts), Design Principles (30pts), Plant Identification (20pts) and Attractiveness/Neatness (20pts).

CLASSES

		<u>Ribbon</u>	<u>Value</u>
1	Landscape Plans, CAD	Blue	200 points
2	Landscape Plans, Hand drawn	Red	100 points
		White	50 points
		HM	No points

*Division Champion \$40, plaque & 400 points

*Division Reserve Champion \$30, plaque & 300 points

FFA FLORAL DESIGN CONTEST

Yvette Smith • Coordinator

229-386-3428

WHEN: Tuesday, October 11

CHECK-IN: 9:30 AM, Heritage Hall

Contest begins: 10:00 AM

DIVISION 32601 FLORAL DESIGN CONTEST

2011 Theme: "The Beauty of Going Green"

*Individuals are limited to **one** entry; chapters are limited to **two** entries in this division..*

1. In the floral design contest, a person who has been declared an FFA Winner as a result of the GNF competition the previous year may not enter the competition again.
2. Contestants will be asked to make a floral design of their choice. It is suggested that the student have in mind exactly what design they will make and practice making the arrangement before the competition. **Students may not use pictures or photos of the arrangement they are creating.**
3. The arrangement may be of any style or design. Novelty and high style designs are encouraged. **Note: 20% of points earned by use of theme in the design.**
4. Contestants must supply all materials, tools, etc., however, nothing can be pre-made prior to the contest.
5. Fresh, silks or dried foliage and flowers, accessories, balloons, etc. may be used.
6. The contest committee will supply a table for the contestant.
7. The finished design should be one unit, just as it would be sold from a florist shop. Any accessories must be contained in or attached to the design.
8. Design must be deliverable.
9. Cost of the design, including any accessories, must be between **\$15 and \$25** based on current wholesale prices. **Contestants should provide an itemized cost sheet of the materials that are used in the arrangement. (All materials must be listed with cost. There can be NO FREE materials.)** The contest coordinator may establish prices for materials if documentation cannot be obtained. It is the responsibility of the contestant to establish prices of non-documented items with the coordinator before the contest begins.
10. Any design exceeding the cost limitation will be disqualified.
11. A **thirty minute** time limit will be enforced. The entire design must be created from start to finish on site.
12. Floral designs will remain on display until pickup time for horticulture exhibits.
13. Floral Designs will be judged as follows: Theme (20 pts), Design (20 pts), Technique & Workmanship (20 pts), Balance & Color Interest (20pts), Functionality (10 pts), and Judges Choice (10pts).

*Division Champion \$100 & plaque

*Division Reserve Champion \$50 & plaque

<u>Ribbon</u>	<u>Value</u>
Blue	400 points
Red	300 points
White	200 points
HM	No points

HORNBUCKLE WHOLESALE FLORIST

A Growing Reputation for Quality ✕ *A Reputation for Quality Growing*

OMEGA, GA MACON, GA LYONS, GA

☎229-528-4215 ☎478-746-3245 ☎912-526-8105

SUPPORTING FFA: Another Group of Excellent Growers

Floral Design Contest Division Champion will receive a \$50 gift certificate and Reserve Champion will receive a \$25 gift certificate from Hornbuckle Wholesale Florist.

HORTICULTURE PLANT ID CONTESTS

Melissa Riley • Coordinator
478-825-6067

WHEN: *New* Tuesday, October 11

CONTEST: 10:00 AM - 2:00 PM

WHERE: *New* ROQUEMORE CENTER

DIVISION 32701 - JUNIOR FLORICULTURE CONTEST (INDIVIDUAL)

DIVISION 32702 - SENIOR FLORICULTURE CONTEST (INDIVIDUAL)

DIVISION 32703 - JUNIOR CHAPTER FLORICULTURE CONTEST (SCHOOL TEAM)

DIVISION 32704 - SENIOR CHAPTER FLORICULTURE CONTEST (SCHOOL TEAM)

DIVISION 32705 - JUNIOR NURSERY LANDSCAPE CONTEST (INDIVIDUAL)

DIVISION 32706 - SENIOR NURSERY LANDSCAPE CONTEST (INDIVIDUAL)

DIVISION 32707 - JUNIOR CHAPTER NURSERY LANDSCAPE CONTEST (SCHOOL TEAM)

DIVISION 32708 - SENIOR CHAPTER NURSERY LANDSCAPE CONTEST (SCHOOL TEAM)

1. Team Composition

A team representing a chapter will consist of four members. Each school may enter a maximum of two teams in each division. If a school does not have a complete team, chapter members may participate as individuals. Chapters are limited to two teams in each division and/or three individuals in each division. ***Only one team*** will be allowed in the overall judging and must be designated at registration. Individual participants and students on designated team will be considered for individual awards. Junior teams will be composed of 6th - 9th grades. Senior teams will be composed of 9th - 12th grades.

NOTE: State winning Floriculture and Nursery/Landscape teams are encouraged to participate in the plant identification contests as practice, but will not be allowed to compete for placings.

2. Identification of Plant Material

Twenty-five specimens from the Georgia Floriculture/Nursery Landscape Plant Identification List will be displayed for contestants to identify. Twenty-five minutes will be allowed for this phase of the contest.

3. Scoring

Scoring for both junior and senior teams will be the same. One point will be awarded for each correct answer. The team score will be the total of the three highest individuals' scores on each team.

4. Tie Breakers

Senior division will use plants, equipment and disorders from FFA CDE list. Junior division will use plants/plant parts from the junior lists.

DIVISIONS 32701, 32702, 32705, 32706

1st	2nd	3rd	4th	5th-7th	8th-10th
\$40	\$30	\$20	\$15	\$10	\$5

*Division Champion (Individual) plaque & 400 points

*Division Reserve Champion (Individual) plaque & 200 points

Chapter Champion (Team) \$100 & plaque
Chapter Reserve Champion (Team) \$50 & plaque
In case of an unbroken tie, money will be split

References:

GEORGIA AGRICULTURE EDUCATION CURRICULUM RESOURCE AND REFERENCE CD AND WEBSITE.

ENVIRONMENTAL EDUCATION, FORESTRY & NATURAL RESOURCES DEPARTMENT

Exhibit Delivery Schedule: Wednesday, Sept. 28 - Saturday, Oct. 1
Weekdays 10:00 AM - 5:00 PM Saturday 10:00 AM - 3:00 PM
***NO SUNDAY DELIVERY**

Arrival deadline on all exhibits: Saturday, October 1, 3:00 PM
No late registrations will be accepted.
Postmark deadline is September 20, 2010.

Release Time: Tuesday, October 18, 10:00 AM - 8:00 PM
Wednesday, October 19, 10:00 AM - 4:00 PM
& Saturday, October 22, 10:00 AM - 3:00 PM

**THE FAIRGROUNDS CANNOT BE RESPONSIBLE FOR THE SAFETY OF
EXHIBITS LEFT AFTER 3:00 PM OCTOBER 22.**

- New* 1. **A teacher/advisor/agent must be present for delivery and pickup of exhibits.**
2. **Exhibitors must be preregistered. Entry forms should be received by September 20, 2011.** Online entries are strongly encouraged. Advisors should call 800-987-3247, ext. 555 or email contests@gnfa.com to obtain required password, which must be obtained by Sept.18, 2011. Registration deadline is Sept. 20, 2011. **Late entries will not be processed.**

**Georgia National
Superior FFA Forestry Chapter
1st Place - \$500 2nd Place - \$250**

The FFA chapter accumulating the most points in the Forestry Department will be the Georgia National Superior FFA Forestry Chapter. The chapter winning these awards will receive \$500 and a plaque. The second place chapter will receive \$250 and a plaque.

FORESTRY CHAPTER DISPLAYS

John Allen Bailey • Coordinator
478-289-2558

DIVISION 34001 FORESTRY CHAPTER DISPLAYS

New Theme - **“Forestry is Naturally Wonderful”**

Ribbon	Value
Blue 700 points	* Champion \$300 & plaque
Red 500 points	* Reserve Champion \$200 & plaque
White 300 points	
HM No points	

1. **PURPOSE:**

A. To encourage teachers and students in Agricultural Education to display the importance of forestry and natural resources education in our schools to the general public.

B. To educate and enlighten the public as to what is being taught to students in Agricultural Education.

2. The exhibit must be an example of the school’s instructional program in forestry and natural resources. It should also tell the story of how the school is meeting the needs of the students in forestry education. **One** entry allowed per school. **Exhibits from previous years may not be entered again for competition.**

3. **JUDGING:** The following scorecard will be used in judging these exhibits.

A. Adherence to theme - 15 pts. The theme is the subject around which the exhibit is developed or the main idea the exhibit is to convey. The 2010 theme is **“Forestry is Naturally Wonderful.”**

B. Quality - 15 pts. Quality refers to the characteristics of the exhibit based on workmanship as well as materials, objects and products used.

C. General Appearance or Attractiveness - 15 pts. The general appearance of an exhibit should be neat and eye-catching. It should have balance and harmony. The combination of form and color should make a good impression.

D. Informational Education Value - 40 pts. The exhibit should contain facts and information that quickly tell a story of importance to its viewers.

E. Creativity and Clarity - 15 pts. The work should be original with a clear message of the theme.

4. **SIZE:** Display area to be a triangle, 4'x4'x5'6", with a two-sided backdrop of unpainted 4'x8' panels hinged together. These panels will be supplied by the Fair and will be in place ready for use by September 28. Chapters may use staples, thumbtacks or small finish nails to attach their exhibit. Use of the floor space within the triangle to create a three-dimensional exhibit is strongly encouraged. There will be a 12" x 5' 6" title board across the top for your use, see sketch below.

5. Chapters are to provide a protective case for displaying loose tools and equipment.

6. Students who graduated last year are eligible to enter work completed in their senior year. Exceptions: Dendrology Notebooks and any contest requiring the student’s presence at the Fair.

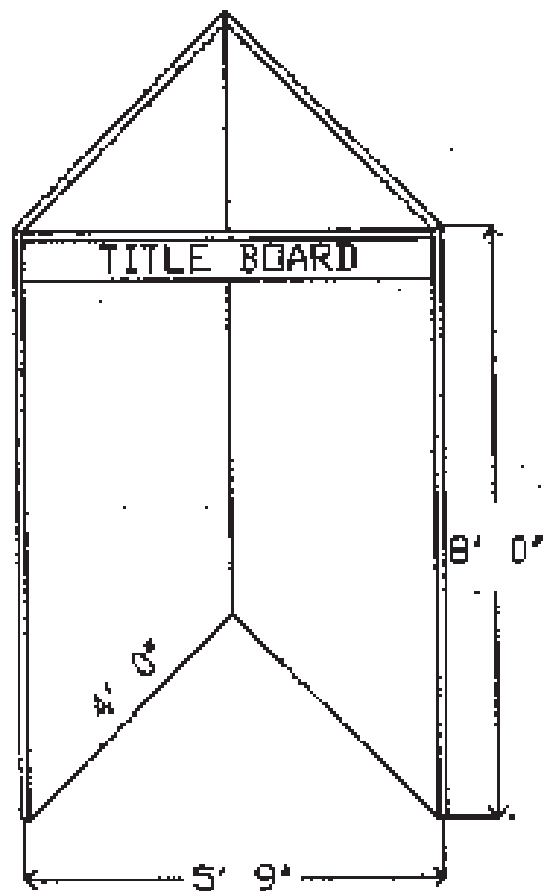

DENDROLOGY NOTEBOOK

John Allen Bailey • Coordinator

478-289-2558

DIVISION 34101 - Junior Dendrology Notebook (Students in the 9th grade and below)

DIVISION 34102 - Senior Dendrology Notebook

1. Each school may enter up to **3 students' leaf collection notebooks in each of the above classes (6 notebooks total)**. The notebook should be the FFA notebook or any other standard hardback notebook. The entire class should use the same type and color notebook.
2. Each junior notebook will contain tree samples from the Junior **Natural Resources CDE tree list only**. Each senior notebook will contain tree samples from the **Forestry CDE Tree List**.
3. Chapter winners will be determined by the combined scores of the top three students' notebooks.
4. Each Senior notebook must contain 40 forest tree species that are listed in the FFA Awards Bulletin. Each Junior notebook must contain 36 forest tree species that are listed in the FFA Awards Bulletin. Each notebook should contain a minimum of six conifers, four of which must include loblolly, longleaf, shortleaf and slash pines. The remaining leaves should be hardwoods. Consideration should be given to trees that are economically important and natural to the area. Extra leaves may be included, but will only be considered for tie-breaking purposes.
5. All notebooks must be original student work, prepared by the student entering the contest. Students must be enrolled in middle school or high school at the time of this competition. Teachers may be asked to verify authenticity of students' work.
6. Each notebook should contain:
 - A. Student's name, school, grade, instructor's name
 - B. Table of contents listing each species in the notebook
 - C. Leaves arranged by conifers and hardwoods
 - D. A written description of the specimen, including common name, descriptive features of the species, key characteristics, wood description, uses and distribution area.

This information should be on the right-hand page of the notebook and the leaf specimen should be on the left-hand page of the notebook.
7. Display will be graded on: neatness, uniformity, quality of specimens, accuracy of identified specimens, quality and originality of descriptions.

	<u>Ribbon</u>	<u>Value</u>
*Junior Division Champion \$40, plaque & 400 points	Blue	200 points
*Junior Division Reserve Champion, \$30, plaque & 300 points	Red	100 points
*Senior Division Champion \$40, plaque & 400 points	White	50 points
*Senior Division Reserve Champion \$30, plaque & 300 points	HM	No points

Dendrology Notebooks**Chapter Champion \$100 & plaque****Chapter Reserve Champion \$50 & plaque**

TREE ID CONTEST

John Allen Bailey • Coordinator
478-289-2552

WHEN: *New* Tuesday, October 11

CONTEST: 10:00 AM - 2:00 PM

WHERE: *New* ROQUEMORE CENTER

DIVISION 34201 - JUNIOR TREE ID CONTEST (INDIVIDUAL)

DIVISION 34202 - SENIOR TREE ID CONTEST (INDIVIDUAL)

DIVISION 34203 - JUNIOR TREE ID CONTEST (SCHOOL TEAM)

DIVISION 34204 - SENIOR TREE ID CONTEST (SCHOOL TEAM)

1. The Tree ID Contest is open to any FFA member who is currently enrolled in grades 6-12. Each school and members are encouraged to have other displays in the Forestry and Natural Resources Department. (Chapter display, minibooths and notebooks.)

2. Each school may enter up to **10 students**. A team representing a chapter will consist of five members. If a school does not have a complete team, or has less than two teams, members may participate as individuals. Team members must be designated before competition begins. **Junior teams will be composed of 6th - 9th grades. Senior teams will be composed of 9th - 12th grades; however a student may compete on only one team.**

3. Contestants should bring a pencil and clipboard. Identification numbers will be written on answer sheet from the list.

4. Each junior member will identify species of trees from a list from the Junior **Natural Resources Career Development Event (CDE)**. Each senior member will identify species from the **Forestry Career Development Event (CDE) list**. Species samples may be the entire tree, small limb, leaf spray, fruit, nuts or a brief description of key characteristics. **Students are required to be present to break ties.**

5. Scoring for both junior and senior teams will be the same. The chapter score is the total of five designated team members.

<u>1st</u>	<u>2nd</u>	<u>3rd</u>	<u>4th</u>	<u>5th-7th</u>	<u>8th-10th</u>
\$40	\$30	\$20	\$15	\$10	\$5

*Division Champion (Individual) plaque & 400 points

*Division Reserve Champion (Individual) plaque & 200 points

Tree ID Contest

Chapter Champion (Team) \$100 & plaque

Chapter Reserve Champion (Team) \$50 & plaque

In case of an unbroken tie, money will be split.

FORESTRY AND NATURAL RESOURCES

MINIBOOTH EXHIBITS

John Allen Bailey • Coordinator
478-289-2552

DIVISION 34301 FORESTRY MINIBOOTH EXHIBIT

Minibooths may be individual or team of two and participants may enter a maximum of **one** entry. **Each chapter is limited to a maximum of five booths.** Exhibits should fit into prebuilt display areas provided by the Fair. The display area will be a triangle 30"x30"x36", with a two-sided backdrop of 30"x24" panels hinged together. **POINTS WILL BE DEDUCTED FOR DISPLAYS EXTENDING BEYOND THESE DIMENSIONS.** The display booths are unpainted plywood and are approximately 30" off the floor. Use of the "floor" of the minibooth to create a three-dimensional exhibit is strongly encouraged. Displays may be stapled, tacked or taped onto the wooden panels. Do not use glue, paint or nails. **NO ELECTRICITY IS AVAILABLE FOR MINIBOOTHES.**

The exhibit tag furnished by the Georgia National Fair should be placed on the upper right-hand corner of the right partition of the exhibit booth. Exhibits from previous years may not be entered again.

Minibooths will be judged on: Theme title (15 pts), Quality (15 pts), Attractiveness (15 pts), Educational Value (40 pts), Creativity and Clarity (15 pts)

	<u>Ribbon</u>	<u>Value</u>
*Division Champion \$100, plaque & 400 points	Blue	200 points
*Division Reserve Champion \$50, plaque & 250 points	Red	100 points
	White	50 points
	HM	No points

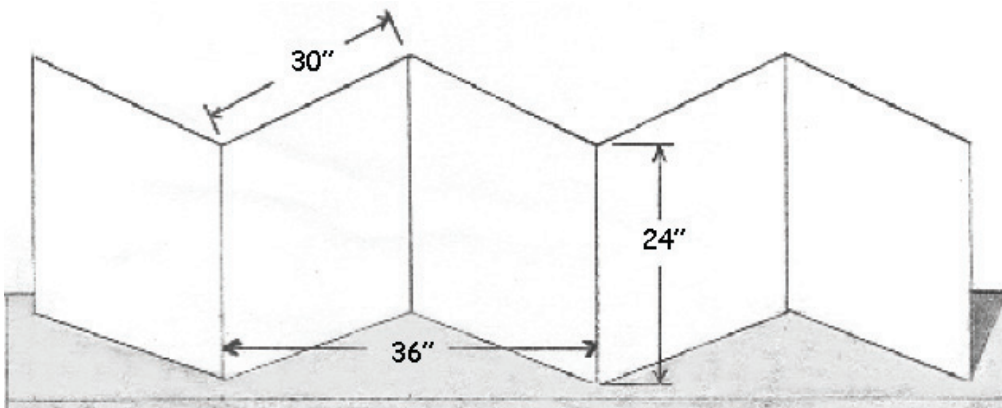

**MINIBOOTH
TABLETOP
DESIGN**